



PREVIERO

SIZE REDUCTION TECHNOLOGY

GRINDERS



GRINDERS APPLICATIONS

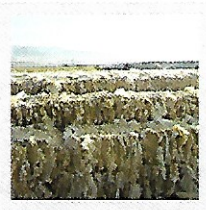

WET GRINDING SYSTEMS

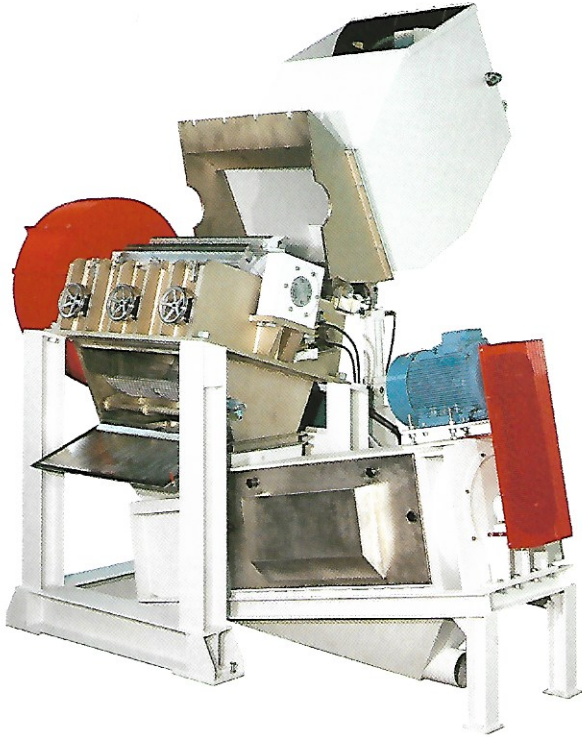

● GRINDER AND CENTRIFUGE FOR PET AND HDPE BOTTLES RECYCLING LINE



● GRINDER AND CENTRIFUGE FOR FILM RECYCLING LINE



● GRINDING AREA FOR PET OR HDPE BOTTLES RECYCLING LINE COMPOSED OF TWO GRINDERS AND TWO CENTRIFUGES

DRY GRINDING SYSTEMS



GRINDER WITH CONVEYOR BELT
LOADING SYSTEM
AND PNEUMATIC TRANSPORT



GRINDER WITH CONVEYOR BELT
LOADING SYSTEM AND CONVEYOR
BELT DISCHARGE



GRINDER WITH CONVEYOR BELT
LOADING SYSTEM AND FIXED HOPPER

GRINDERS APPLICATIONS

BI-ORIENTED AND CAST LINE FILM

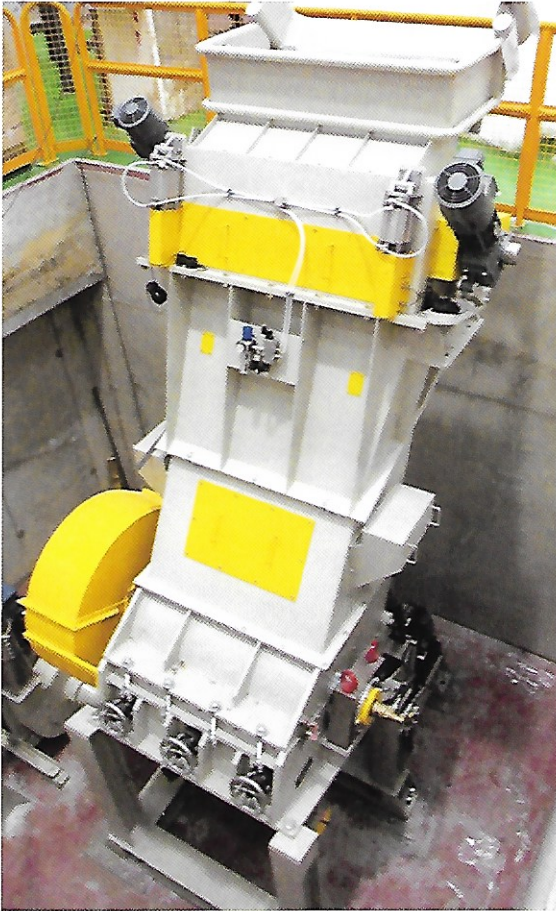

GRINDER WITH
AUTOMATIC
FEEDER



DOUBLE BELT
FEEDING
SYSTEM

EDGE TRIMS



IN-LINE RECOVERY OF EDGE-TRIMS



VERTICAL FEEDING FOR PNEUMATIC TRANSPORT



EDGE -TRIMS SUCTION



LARGE DIAMETER PIPES AND PROFILES

HORIZONTAL FEEDING

HORIZONTAL CHANNEL FEEDING
UP TO 6,5 MT LENGHT

PIPES Ø	MODEL
Ø 650	100/80 TO
Ø 850	120/100 TO
Ø 1350	180/150 TO

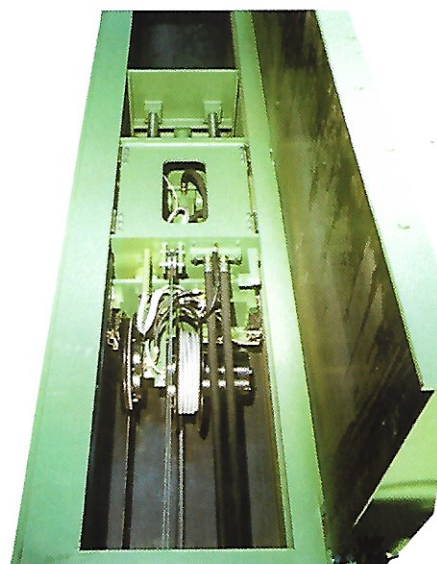
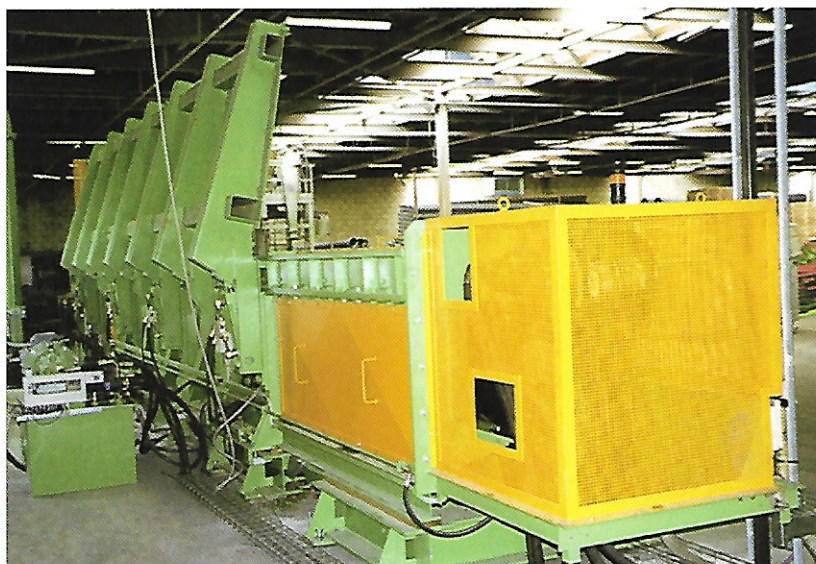
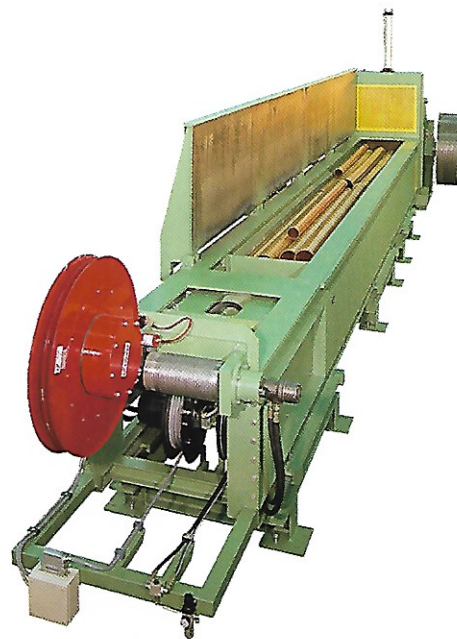

PIPES AND PROFILES

LATERAL FEEDING

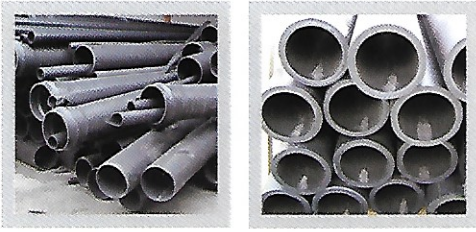

HOPPER FOR LATERAL LOADING OF PIPES AND PROFILES

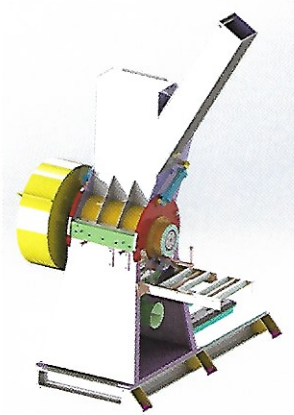
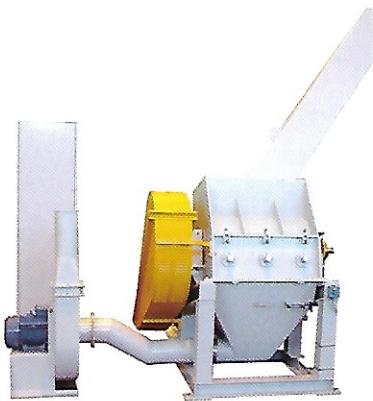

TILTING HOPPER

GRINDERS APPLICATIONS



SHEETS AND ROLLS

GRINDERS TYPE AS

THE OLEODYNAMIC TILTING OF THE CUTTING CHAMBER ENSURES AN EXTRAORDINARY EASY ACCESS AND CLEANING WHICH CANNOT BE COMPARED WITH THE TRADITIONAL GRINDERS.

SUITABLE FOR HIGH PRODUCTIONS AND FREQUENT COLOR CHANGE AND MATERIALS.

2 MODELS AVAILABLE:

- MU 420 AS with \varnothing 400 x 2000 mm rotor
- MU 816 AS with \varnothing 800 x 1600 mm rotor







HOPPER FOR SHEETS LOADING

HEAVY DUTY GRINDER

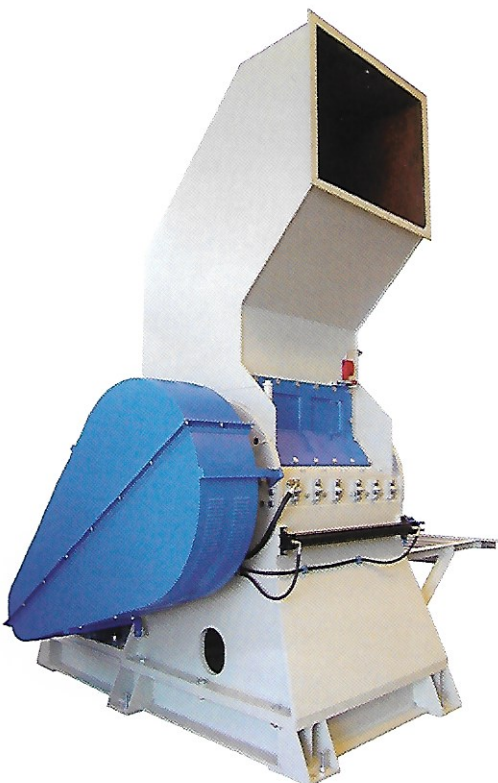

LARGE SIZE BLOCKS OF PLASTIC AND RUBBER



MODELS "P" SERIES			
MU 712	Ø 700 x 1200	P4	P6
MU 715	Ø 700 x 1500	P4	P6

- SUITABLE FOR MOST DIFFICULT APPLICATIONS AND WITH HEAVY LOADING OVERDIMENSIONED MECHANICS.
- ESPECIALLY INDICATED FOR BLOCKS.

GRINDERS CHARACTERISTIC & ROTORS

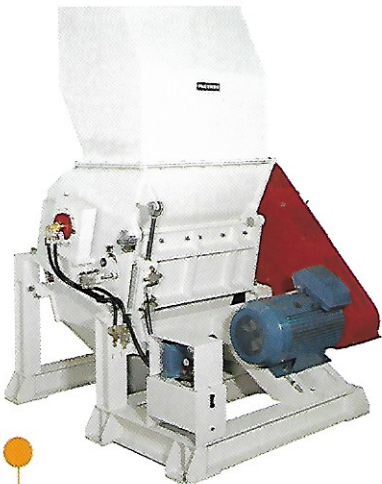

SUPPORTING CHASSIS FOR GRINDER, MOTOR, HYDRAULIC UNIT

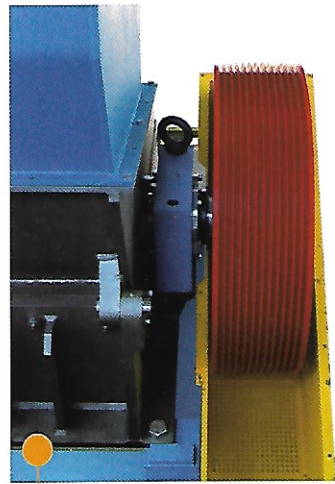

BIG DIAMETER PULLEY WITH HIGH MOMENT OF INERTIA. STRONG BELT COVER WITH INSPECTION DOOR OPENABLE IN TWO HALVES

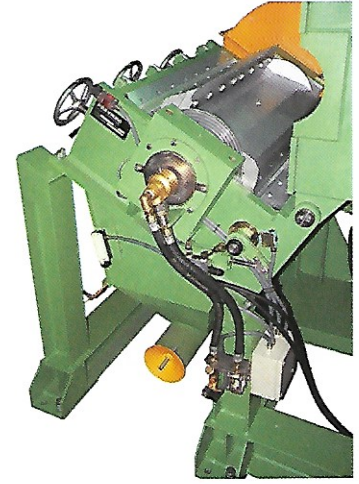

SLANTED AND BOLTED FIXED BLADES FOR PROGRESSIVE CUT. EASY ACCESS TO THE CUTTING CHAMBER FOR CLEANING AND BLADE CHANGE

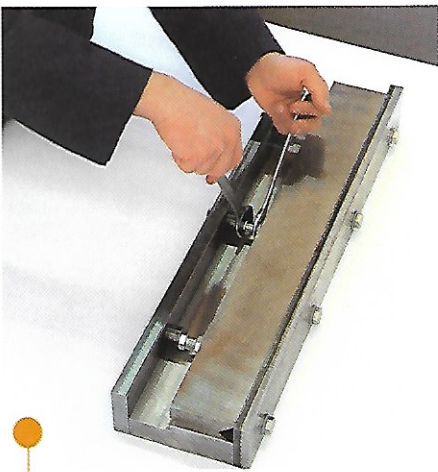

PREADJUSTMENT OF ROTARY AND FIXED BLADES

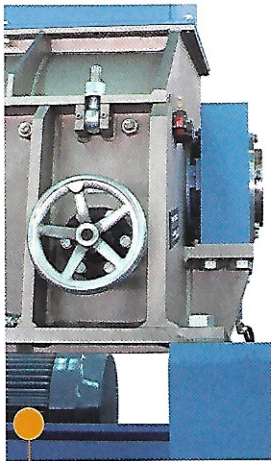

EXTERNAL BEARING SUPPORTS WITH SEAL LABYRINTH

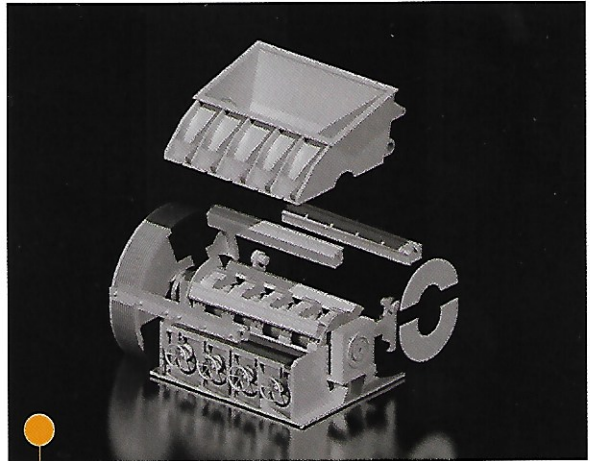

INTERCHANGEABLE ANTI-WEAR PARTS

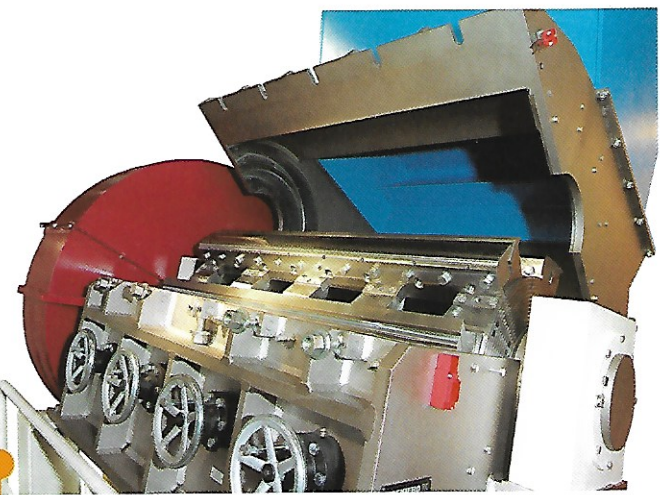

OPEN ROTOR WITH INCLINED ROTATING BLADES FOR DOUBLE HELIX CUT



MECHANICAL LOCKING OF THE DRAWER HYDRAULIC UNIT FOR THE OPENING OF THE GRATE AND HOPPER

GRINDERS TYPE R/RPH

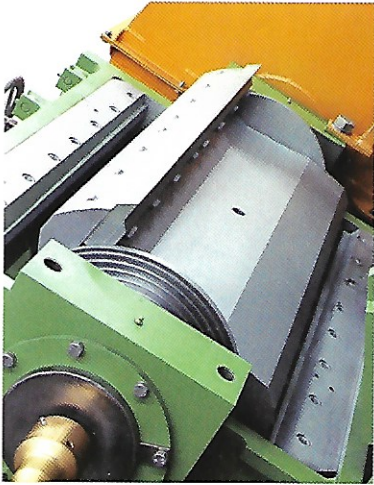

SEMI-OPEN ROTOR WITH SCREW
LOCKED BLADES



OPEN ROTOR WITH SCREW LOCKED
BLADES

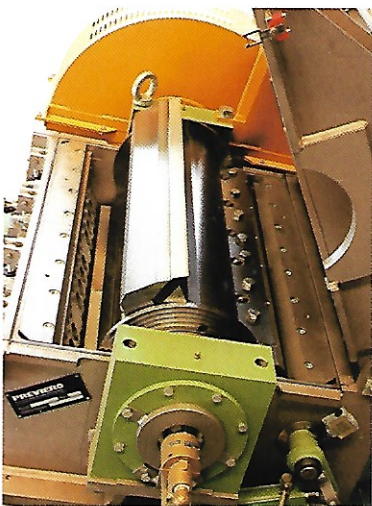

ROTOR WITH INTERCHANGEABLE
ROTATING BLADE SUPPORTS AND
WEDGE LOCKING, AVAILABLE IN OPEN
AND CLOSE VERSION

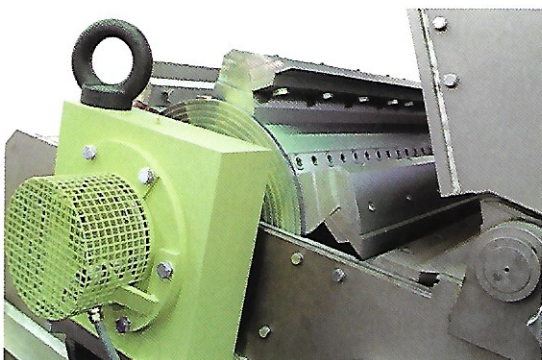

ROTOR WITH INTERCHANGEABLE RO-
TATING BLADE SUPPORTS AND SCREW
LOCKING

GRINDERS TYPE R/PRH

MODELS AVAILABLE





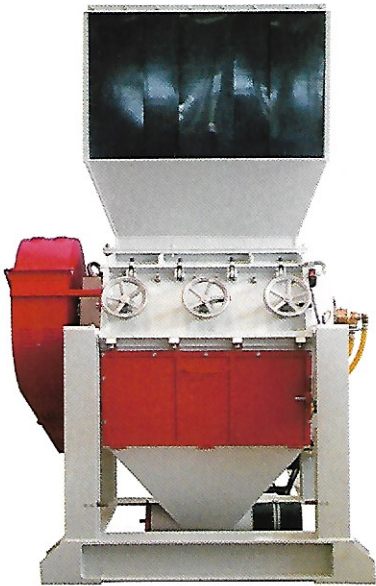

MODELS "R" SERIES				
MU 508	Ø 450 x 800	MU 508 R3	MU 508 R5	MU 508 R5



MODELS "R / PRT" SERIES				
MU 610	Ø 550 x 1000	MU 610 R3	MU 610 PRT	MU 610 R5

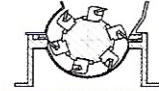

MODELS "R/PRH" SERIES				
MU 812	Ø 750 x 1200	MU 812 R5	MU 812 PRH	-
MU 816	Ø 750 x 1600	-	-	MU 816 PRH

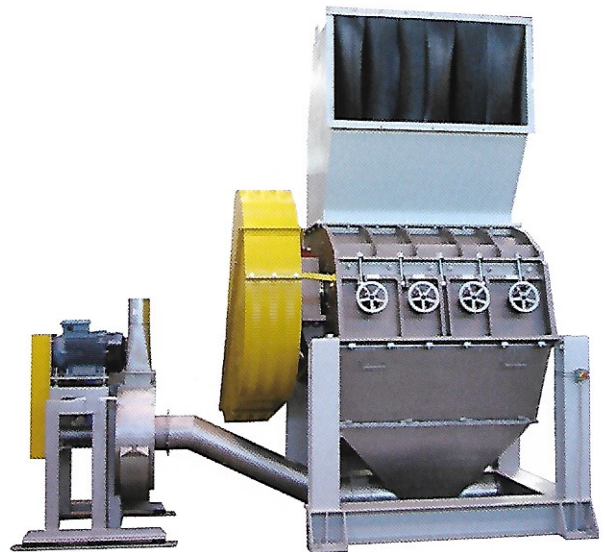
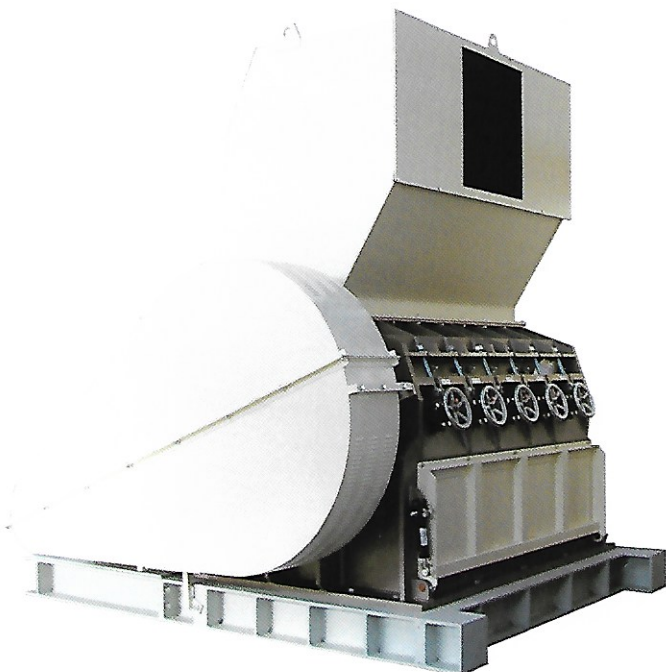

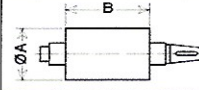
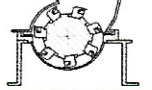
MODELS "R/PRH" SERIES		
MU 916	Ø 850 x 1600	MU 916 PRH
MU 920	Ø 850 x 2000	MU 920 PRH

GRINDERS CHARACTERISTIC & ROTORS



● HYDRAULIC OPENING OF THE HOPPER

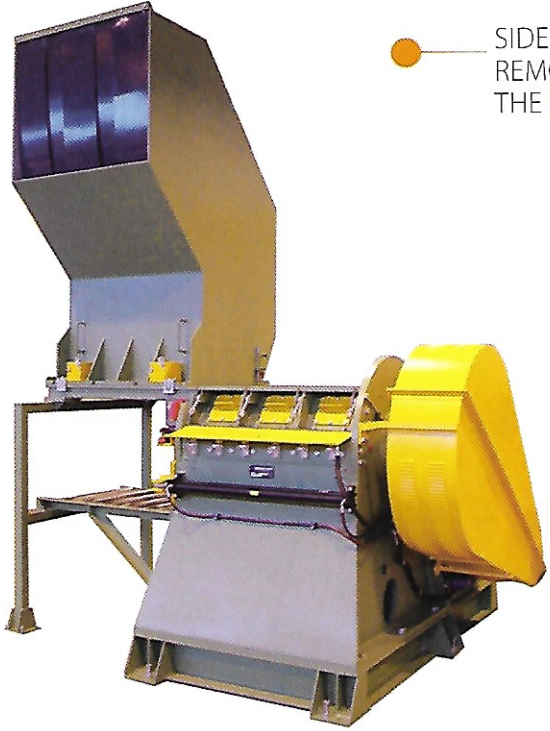

● SIDE REMOVAL OF THE HOPPER

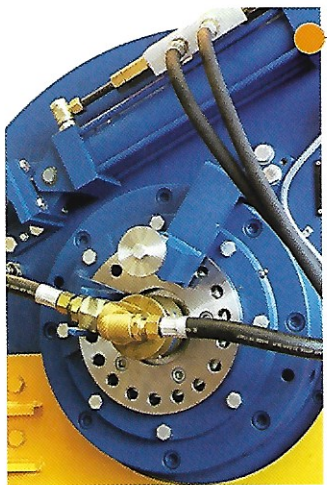

● ROTOR BLOCKING

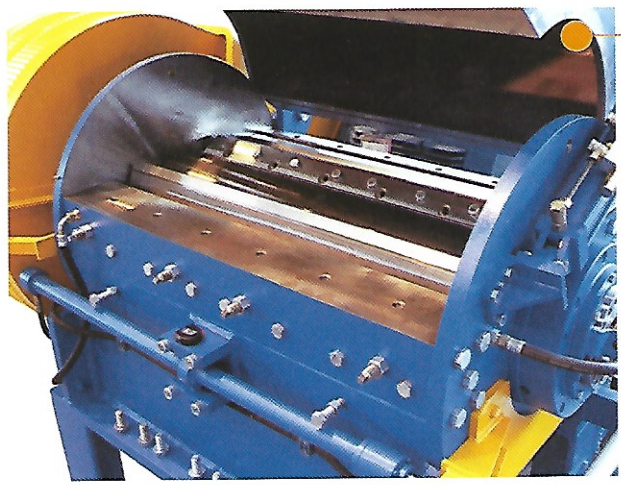

● EASY ACCESS TO THE CUTTING CHAMBER FOR CLEANING AND BLADE CHANGE

PREADJUSTMENT OF ROTATING AND FIXED BLADES

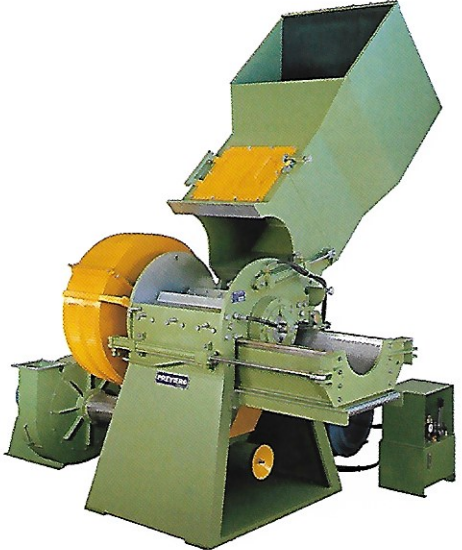

● HYDRAULIC SIDE REMOVAL OF THE GRATE

GRINDERS TYPE N/M/MS/P

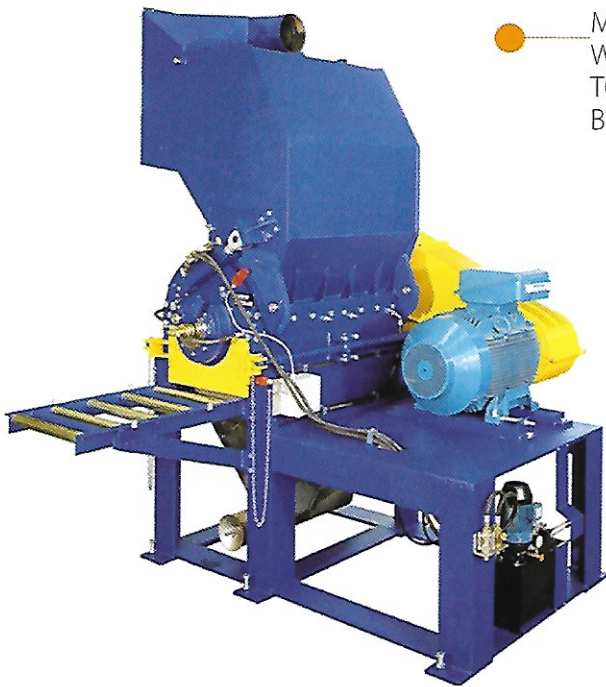

MOTOR WITH SLIDE TO ADJUST BELT TENSION

ROTATING AND FIXED BLADES WEDGE BLOCKING

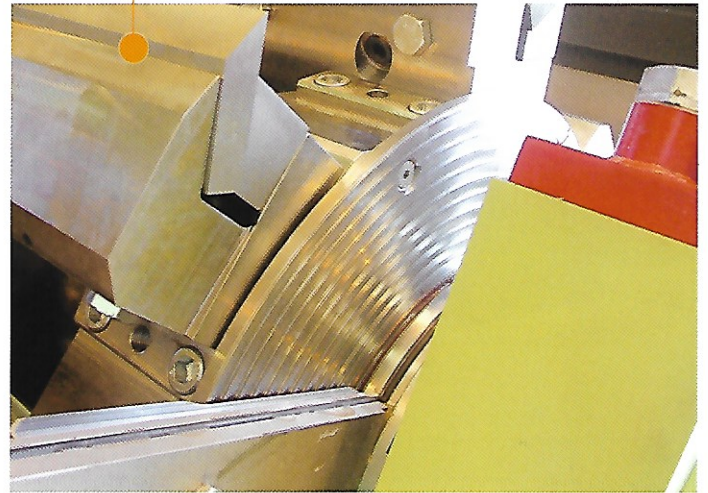

ROTOR WITH INTERCHANGEABLE BLADES SUPPORT

ROTOR AND FIXED BLADES WATER COOLING

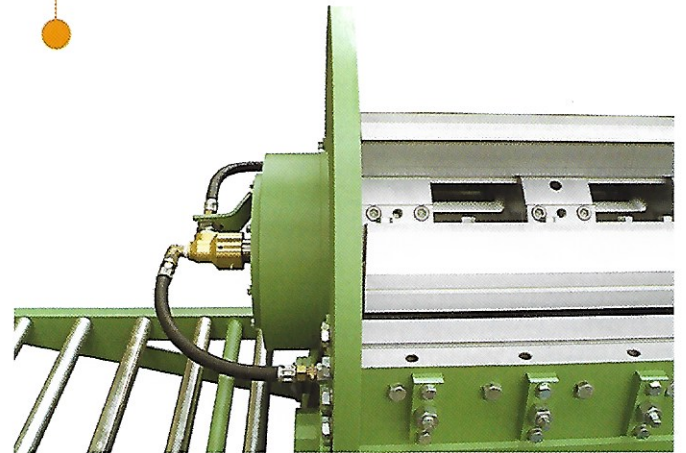
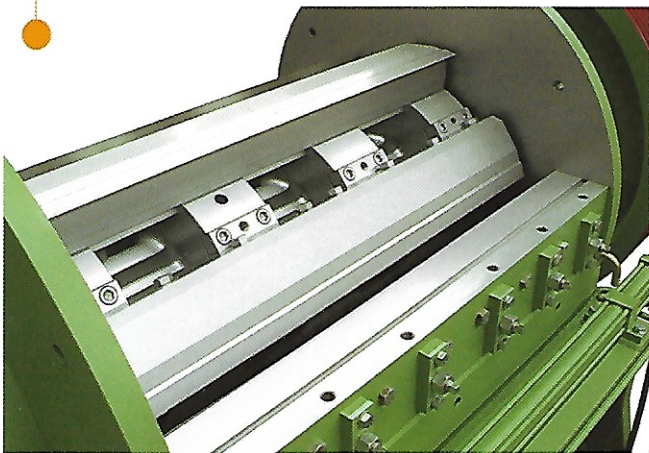

DIMENSIONED BEARING SUPPORTS FOR HIGH LOADS

BIG DIAMETER PULLEY WITH HIGH MOMENT OF INERTIA

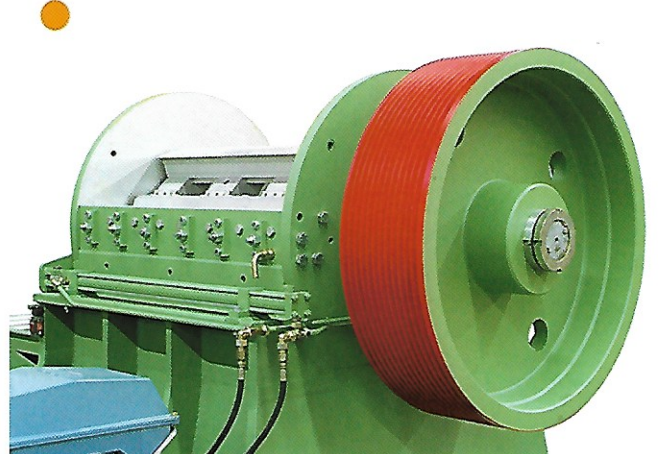
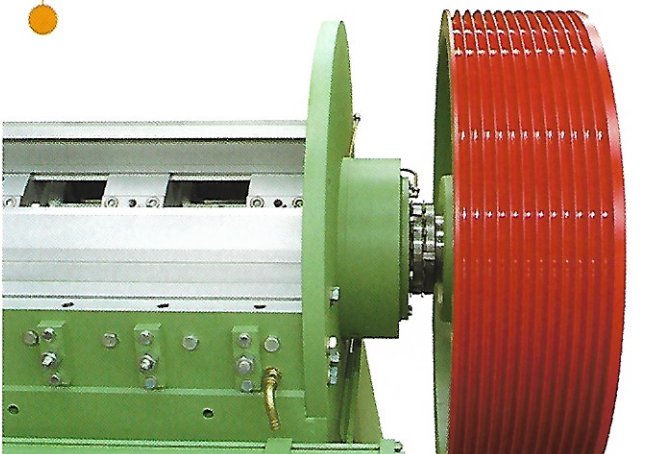

GRINDERS TYPE N/M



"N" SERIES

- SUITABLE FOR ALL PRODUCTION REQUIREMENTS.
- FLEXIBLE, EASY TO INSTALL.

MODELS "N" SERIES				
MU 305	Ø 300 x 500	N 3	-	-
MU 408	Ø 400 x 800	N 3	N 5	N 5/3
MU 412	Ø 400 x 1200	N 3	N 5	N 5/3

MODELS "M" SERIES					
MU 508	Ø 500 x 800	M 3	M 5	-	M 3R
MU 512	Ø 500 x 1200	M 3	M 5	M 5/3	M 3R
MU 515	Ø 500 x 1500	M 3	M 5	M 5/3	M 3R

"M" SERIES

- PROPER FOR RUBBER AND DIFFICULT PLASTIC WASTES RECYCLING.
- SUITABLE FOR OTHER MATERIAL AS CELLULOSE, WOOD, LIGHT METALS AND CABLES



GRINDERS TYPE MS/P

MODELS AVAILABLE

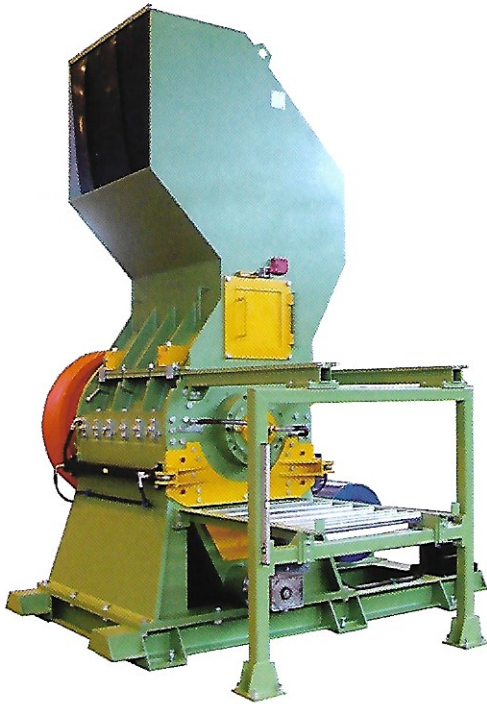

"MS" SERIES

- SUITABLE GRINDERS FOR HIGH PRODUCTIONS AND AUTOMATED PLANTS
- HIGH OUTPUTS, LOW ENERGY CONSUMPTIONS

MODELS "MS" SERIES			
MU 712	Ø 700 x 1200	MS4	MS6
MU 715	Ø 700 x 1500	MS4	MS6

MODELS "P" SERIES			
MU 712	Ø 700 x 1200	P4	P6
MU 715	Ø 700 x 1500	P4	P6

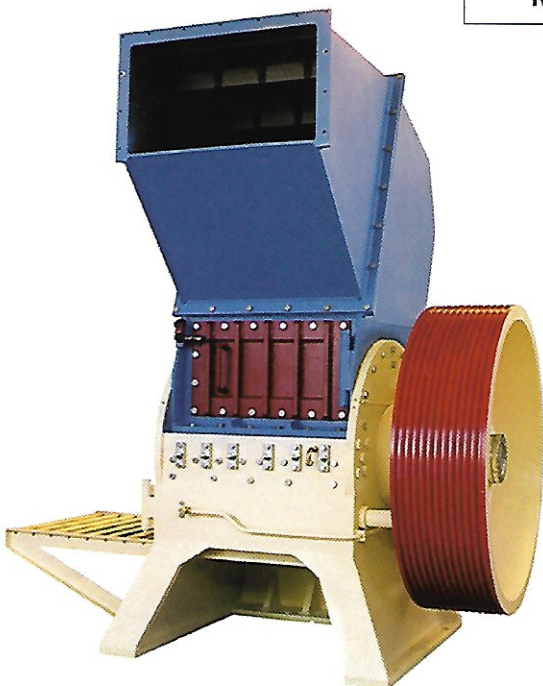

"P" SERIES

- SUITABLE FOR MOST DIFFICULT APPLICATIONS AND WITH HEAVY LOADING OVERDIMENSIONED MECHANICS.
- ESPECIALLY INDICATED FOR BLOCKS.

GRINDERS OPTIONS & ACCESSORIES



SOUNDPROOFING CABINS

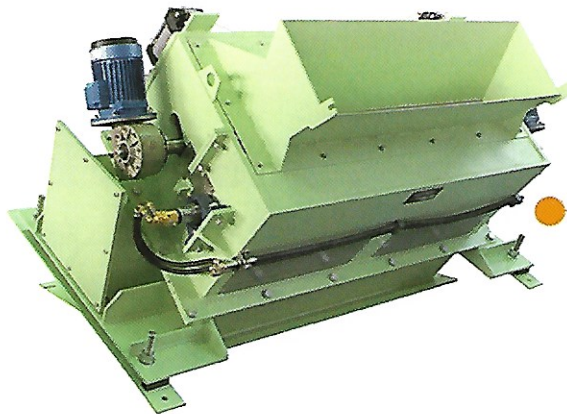

ROLLERS FEEDER



MIXING AND STORAGE SILO

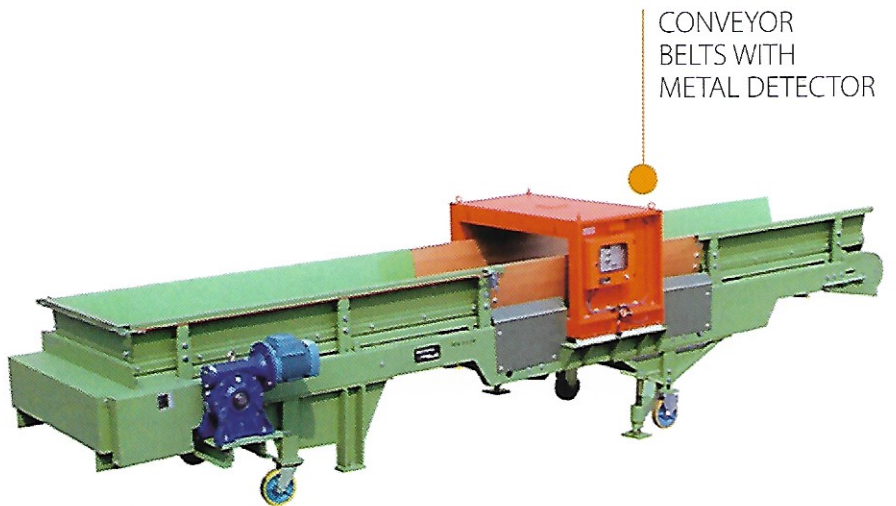

CONVEYOR BELTS WITH METAL DETECTOR



BIG BAG FILLING STATION



ELUTRIATOR

GUILLOTINE



MAGNETIC OVERBELT

PREVIERO

SIZE REDUCTION TECHNOLOGY

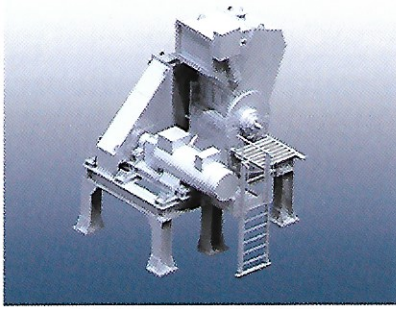

RUBBER GRINDERS

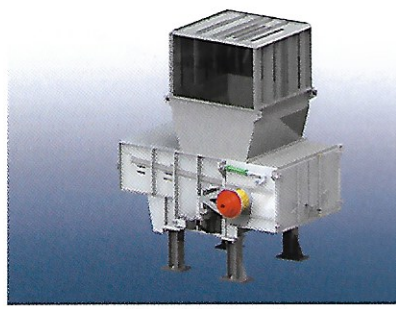

SHREDDERS

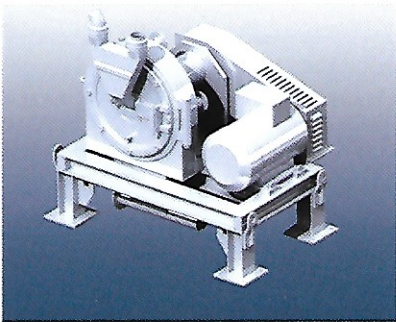

PULVERIZERS

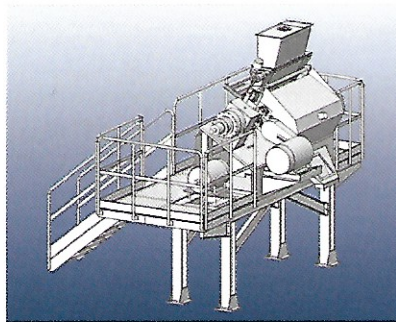

CUBE DICERS



COMPLETE
SYSTEM
FOR SIZE
REDUCTION

RUBBER GRINDERS

SHREDDERS

GRINDERS

PULVERIZERS

STRAND
PELLETIZERS

CUBE DICERS

SOREMA

PLASTICS RECYCLING SYSTEMS



PET BOTTLES



MIXED PLASTICS



PE/PP FILM



HDPE BOTTLES



MODULES FOR
RECYCLING
PROCESS

COMPLETE TURN
KEY SYSTEMS FOR:

PET/HDPE BOTTLES

PS/PP/PE
RIGID PLASTICS

MIXED PLASTICS

POST CONSUMER
FILM

AGRICULTURAL
FILM

VIA PER CAVOLTO, 17 • 22040 ANZANO DEL PARCO (CO) • ITALY
TEL. +39 031 63491250
sales@previero.it • sales@sorema.it • www.previero.it • www.sorema.it

Previero reserve the right to make changes to the machines in order to improve their operation.
The data of this catalogue must be therefore understood as informative.